

Metering Valves

MS, MV, ML and MH Series

Needle Valves
Metering Valves



Features

MS Series

- ⦿ Working pressure up to: 2000 psig (138 bar)
- ⦿ Working temperature: -10°F to 400°F (-23°C to 204°C)
- ⦿ Orifice size: 0.032" (0.81 mm)
- ⦿ Max. flow coefficient (Cv): 0.004
- ⦿ Stem taper: 1°
- ⦿ Turns to open: 9 to 12
- ⦿ Shutoff service: not available
- ⦿ Bottom mounting available
- ⦿ Variety of end connections
- ⦿ Panel mountable
- ⦿ Flow pattern: straight, angle, cross and double
- ⦿ Handle type: knurled, vernier and slotted
- ⦿ Variety of materials available for valve body



MV and ML Series

- ⦿ Working pressure up to: 1000 psig (69 bar)
- ⦿ Working temperature: -10°F to 400°F (-23°C to 204°C)
- ⦿ Max. flow coefficients (Cv):
 - MV series: 0.03
 - ML series: 0.15
- ⦿ Orifice sizes:
 - MV series: 0.056" (1.42 mm)
 - ML series: 0.128" (3.25 mm)
- ⦿ Stem taper:
 - MV series: 3°
 - ML series: 6.5°
- ⦿ Turns to open:
 - MV series: 8 to 10
 - ML series: 10 to 11
- ⦿ Shutoff service:
 - MV series: not available
 - ML series: available
- ⦿ Variety of end connections
- ⦿ Panel mountable
- ⦿ Flow pattern: straight, angle, cross (MV Series) and double (MV Series)
- ⦿ Handle type:
 - MV series: knurled, vernier and slotted
 - ML series: round and vernier
- ⦿ Variety of materials available for valve body



B-118 Metering Valves

MH Series

- ⊙ Working pressure up to: 5000 psig (345 bar)
- ⊙ Working temperature: -65°F to 850°F (-54°C to 454°C)
- ⊙ Orifice size: 0.062" (1.6 mm)
- ⊙ Max. flow coefficient(Cv): 0.04
- ⊙ Stem taper: 2°
- ⊙ Turns to open: 9 to 10
- ⊙ Shutoff service: available
- ⊙ Variety of end connections
- ⊙ Panel mountable
- ⊙ Flow pattern: straight and angle
- ⊙ Handle type: round circular and vernier
- ⊙ Variety of materials available for valve body



Pressure vs. Temperature

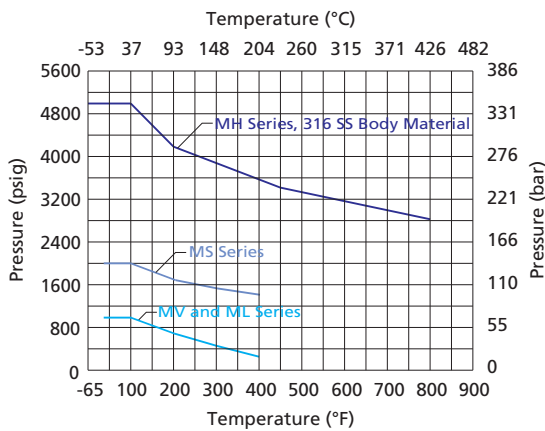

1. Graphs are based on Fluorocarbon and Graphite (for MH Series).
2. Contact FITOK Group or our authorized distributors for curve graph of other materials.

Temperature Ranges for Different Seal Materials

Seal Material	Temperature Range °F (°C)
O-Ring (for MS, MV, ML Series)	
Buna N (NBR)	-10 to 212 (-23 to 100)
Ethylene Propylene (EPDM)	-10 to 300 (-23 to 148)
Fluorocarbon (FKM)	-10 to 400 (-23 to 204)
FFKM	-10 to 527 (-23 to 275)
Neoprene (CR)	-10 to 250 (-23 to 121)
Stem Packing (for MH Series)	
PTFE	-65 to 450 (-54 to 232)
Graphite	-65 to 850 (-54 to 454)

Standard Materials of Construction

MS Series

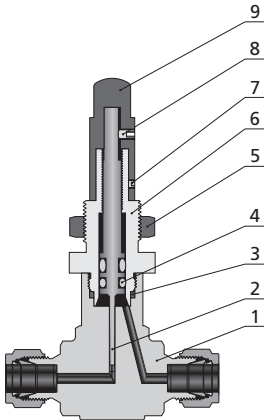

Component		Valve Body Material Grade/ASTM Specification	
		316 SS	Brass
1	Body	316 SS/A182	Silver-mist chrome-plated C37700/B283
2	Stem	316 SS/A479	
3	Body Seal	Fluorocarbon FKM	
4	O-ring	Fluorocarbon FKM	
5	Panel Mount Nut	Stainless steel	Silver-mist chrome-plated C36000/B16
6	Bonnet	316 SS/A479	Silver-mist chrome-plated C36000/B16
7	Lock Screw	Stainless steel	
8	Handle Screw	Stainless steel	
9	Handle	316 SS/A276	Silver-mist chrome-plated C36000/B16

Note: Adjusting the valve at a relatively low position may damage the valve body and stem tip.

MV Series

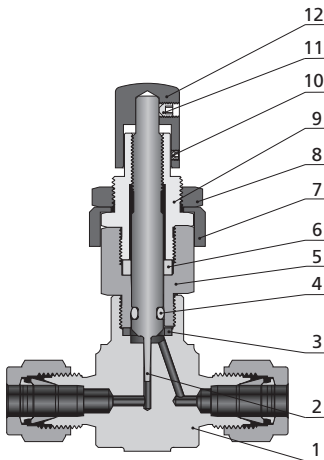

Component		Valve Body Material Grade/ASTM Specification	
		316 SS	Brass
1	Body	316 SS/A182	Silver-mist chrome-plated C37700/B283
2	Stem	316 SS/A479	
3	Body Seal	Fluorocarbon FKM	
4	O-ring	Fluorocarbon FKM	
5	Body Extension	316 SS/A479	Silver-mist chrome-plated C36000/B16
6	Stem Guide Ring	PTFE/D1710	
7	Bonnet Sleeve	Stainless steel	
8	Panel Mount Nut	316 SS/A276	Silver-mist chrome-plated C36000/B16
9	Bonnet	316 SS/A479	Silver-mist chrome-plated C36000/B16
10	Lock Screw	Stainless steel	
11	Handle Screw	Stainless steel	
12	Handle	316 SS/A276	Silver-mist chrome-plated C36000/B16

B-120 Metering Valves

ML Series

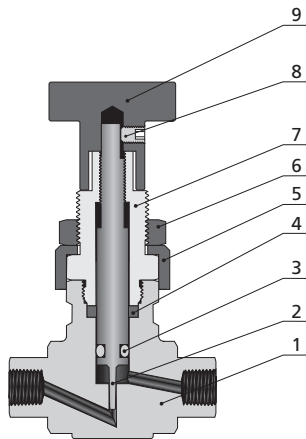

Component		Valve Body Material Grade/ASTM Specification	
		316 SS	Brass
1	Body	316 SS/A182	Silver-mist chrome-plated C37700/B283
2	Stem	Hardened 316 SS/A479	
3	O-ring	Fluorocarbon FKM	
4	Stem Guide Ring	PTFE/D1710	
5	Bonnet Sleeve	Stainless steel	
6	Panel Mount Nut	316 SS/A276	Silver-mist chrome-plated C36000/B16
7	Bonnet	316 SS/A479	Silver-mist chrome-plated C36000/B16
8	Handle Screw	Stainless steel	
9	Handle	Anodized aluminium	

1. Lubricants: Silicone-based

2. Contact FITOK Group or our authorized distributors for other materials.

MH Series

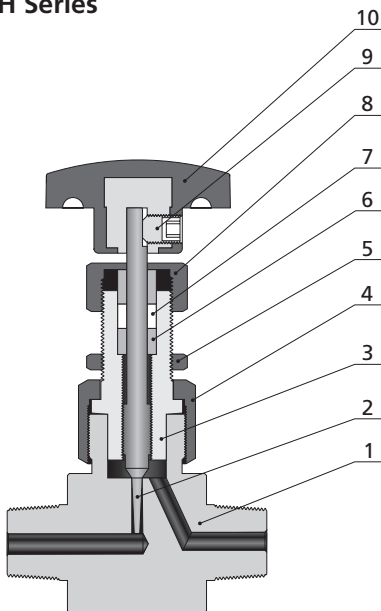

Component		Material Grade/ASTM Specification
1	Body	316 SS/A479
2	Stem	440C SS/A276
3	Bonnet	316 SS/A479
4	Union Nut	316 SS/A276
5	Panel Mount Nut	Stainless steel
6	Packing Gland	316 SS/A276
7	Packing	PTFE/D1710
8	Union Nut	316 SS/A276
9	Handle Screw	Stainless steel
10	Handle	Nylon

Lubricant: Silicone-based

Flow Data in Full Open Position at 70°F (20°C)

Pressure Drop to Atmosphere psig (bar)	MS Series (Cv: 0.004)		MV Series (Cv: 0.03)		ML Series (Cv: 0.15)		MH Series (Cv: 0.04)	
	Air Flow std ft ³ /min (std L/min)	Water Flow U.S. gal/min (L/min)	Air Flow std ft ³ /min (std L/min)	Water Flow U.S. gal/min (L/min)	Air Flow std ft ³ /min (std L/min)	Water Flow U.S. gal/min (L/min)	Air Flow std ft ³ /min (std L/min)	Water Flow U.S. gal/min (L/min)
10 (0.69)	0.04 (1.1)	0.01 (0.03)	0.33 (9.3)	0.09 (0.34)	2.00 (56.6)	0.51 (1.90)	0.45 (12.7)	0.12 (0.45)
50 (3.45)	0.10 (2.8)	0.02 (0.07)	0.90 (25.4)	0.21 (0.79)	6.40 (181)	1.20 (4.50)	1.20 (33.9)	0.28 (1.00)
100 (6.90)	0.20 (5.6)	0.04 (0.15)	1.50 (42.4)	0.30 (1.10)	11.40 (323)	1.70 (6.40)	2.10 (59.4)	0.40 (1.50)

Flow Coefficient at Turns to Open

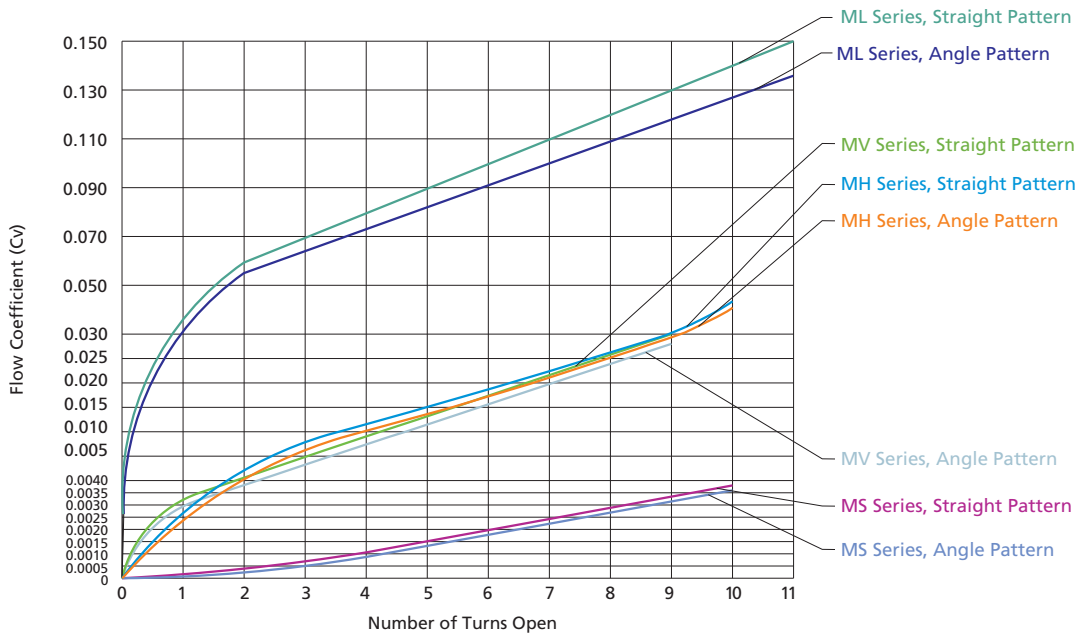

Needle Valves
Metering Valves

Dimensions

MS Series

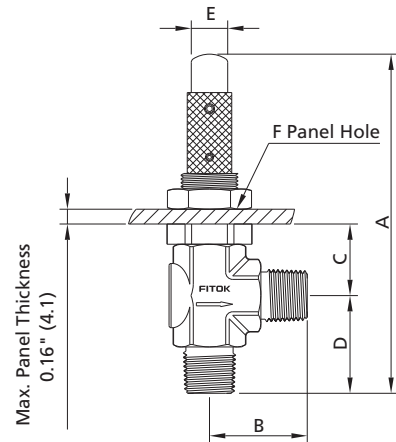
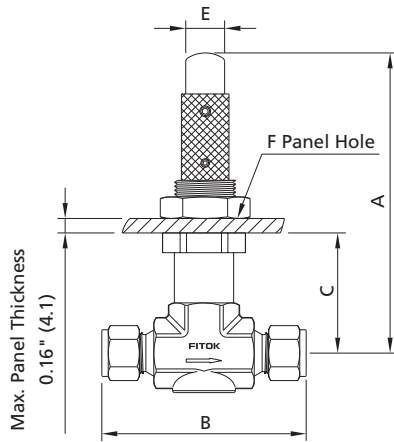

Basic Ordering Number	Connection Type and Size		Dimensions, in. (mm)					
	Inlet	Outlet	A	B	C	D	E	F
Straight Pattern								
MS□□-FL1-	1/16" FITOK	1/16" FITOK	2.34 (59.4)	1.56 (39.6)	0.92 (23.4)	—	0.38 (9.6)	0.45 (11.4)
MS□□-FL2-	1/8" FITOK	1/8" FITOK		2.04 (51.8)				
MS□□-FL4-	1/4" FITOK	1/4" FITOK						
MS□□-ML3-	3 mm FITOK	3 mm FITOK						
MS□□-ML6-	6 mm FITOK	6 mm FITOK						
MS□□-FR4-	1/4 Male FR	1/4 Male FR	2.06 (52.3)					
Angle Pattern								
MS□□-FL1-	1/16" FITOK	1/16" FITOK	2.96 (75.2)	0.81 (20.6)	0.92 (23.4)	0.88 (22.4)	0.38 (9.6)	0.45 (11.4)
MS□□-FL2-	1/8" FITOK	1/8" FITOK	3.07 (78.0)	0.98 (24.9)		0.98 (24.9)		
MS□□-FL4-	1/4" FITOK	1/4" FITOK	3.11 (79.0)	1.02 (25.9)		1.02 (25.9)		
MS□□-ML3-	3 mm FITOK	3 mm FITOK	3.07 (78.0)	0.98 (24.9)		0.98 (24.9)		
MS□□-FNS2-	1/8 Female NPT	1/8 Female NPT						

MV and ML Series

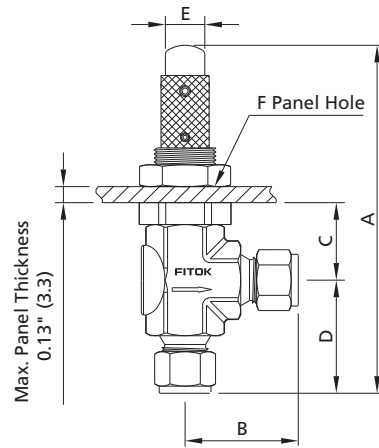
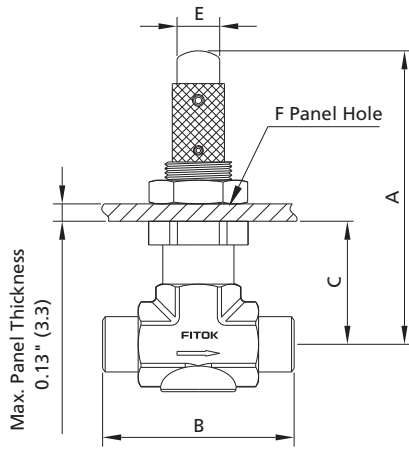

Basic Ordering Number	Connection Type and Size		Dimensions, in. (mm)					
	Inlet	Outlet	A	B	C	D	E	F

Straight Pattern

MV□□-FL2-	1/8" FITOK	1/8" FITOK	2.64 (67.1)	2.02 (51.3)	1.52 (38.5)	—	0.50 (12.7)	0.58 (14.7)
MV□□-FL4-	1/4" FITOK	1/4" FITOK		2.20 (55.9)				
MV□□-ML3-	3 mm FITOK	3 mm FITOK		2.02 (51.3)				
MV□□-ML6-	6 mm FITOK	6 mm FITOK		2.20 (55.9)				
MV□□-NS2-	1/8 Male NPT	1/8 Male NPT		1.60 (40.6)				
MV□□-NS4-	1/4 Male NPT	1/4 Male NPT		1.96 (49.8)				
MV□□-FNS2-	1/8 Female NPT	1/8 Female NPT		1.94 (49.3)				
MV□□-FR4-	1/4 Male FR	1/4 Male FR		2.06 (52.3)				

Angle Pattern

MV□□-FL2-	1/8" FITOK	1/8" FITOK	3.65 (92.8)	1.01 (25.7)	1.07 (27.2)	1.01 (25.7)	0.50 (12.7)	0.58 (14.7)
MV□□-FL4-	1/4" FITOK	1/4" FITOK	3.74 (95.0)	1.10 (27.9)		1.10 (27.9)		
MV□□-ML3-	3 mm FITOK	3 mm FITOK	3.65 (92.8)	1.01 (25.7)		1.01 (25.7)		
MV□□-ML6-	6 mm FITOK	6 mm FITOK	3.74 (95.0)	1.10 (27.9)		1.10 (27.9)		
MV□□-NS2-	1/8 Male NPT	1/8 Male NPT	3.44 (87.4)	0.80 (20.3)		0.80 (20.3)		
MV□□-NS4-	1/4 Male NPT	1/4 Male NPT	3.62 (92.0)	0.98 (24.9)		0.98 (24.9)		
MV□□-FNS2-	1/8 Female NPT	1/8 Female NPT	3.61 (91.7)	0.97 (24.6)		0.97 (24.6)		
MV□□-FR4-	1/4 Male FR	1/4 Male FR						

Basic Ordering Number	Connection Type and Size		Dimensions, in. (mm)					
	Inlet	Outlet	A	B	C	D	E	F

Straight Pattern

ML□□-FL4-	1/4" FITOK	1/4" FITOK	2.72 (69.1)	2.34 (59.4)	1.26 (32.0)	—	1.13 (28.7)	0.58 (14.7)
ML□□-FL6-	3/8" FITOK	3/8" FITOK		2.46 (62.5)				
ML□□-ML6-	6 mm FITOK	6 mm FITOK		2.34 (59.4)				
ML□□-NS4-	1/4 Male NPT	1/4 Male NPT		2.00 (50.8)				

Angle Pattern

ML□□-FL4-	1/4" FITOK	1/4" FITOK	3.89 (98.8)	1.17 (29.7)	1.26 (32.0)	1.17 (29.7)	1.13 (28.7)	0.58 (14.7)
ML□□-ML6-	6 mm FITOK	6 mm FITOK						

MH Series

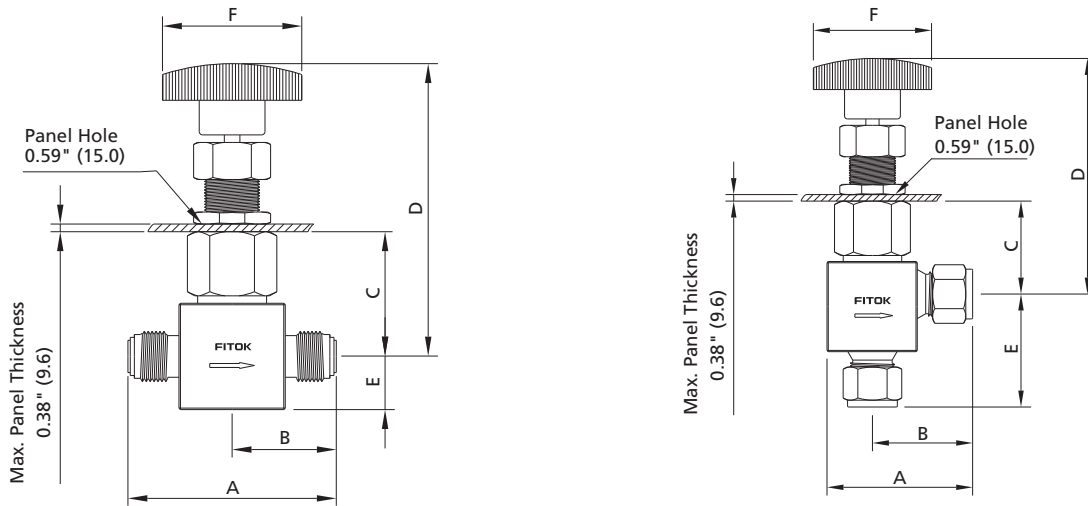

Basic Ordering Number	Connection Type and Size		Dimensions, in. (mm)						
	Inlet	Outlet	A	B	C	D	E	F	
Straight Pattern									
MH□□-FL4-	1/4" FITOK	1/4" FITOK	2.40 (61.0)	1.20 (30.5)	1.09 (27.7)	3.86 (98.0)	1.38 (35.1)	0.38 (9.6)	
MH□□-ML6-	6 mm FITOK	6 mm FITOK						0.40 (10.1)	
MH□□-FNS2-	1/8 Female NPT	1/8 Female NPT						2.00 (50.8)	1.00 (25.4)
MH□□-FNS4-	1/4 Female NPT	1/4 Female NPT						2.06 (52.3)	1.03 (26.2)
Angle Pattern									
MH□□-FL4-	1/4" FITOK	1/4" FITOK	1.54 (39.1)	1.16 (29.5)	1.09 (27.7)	3.86 (98.0)	1.38 (35.1)	1.48 (37.6)	
MH□□-ML6-	6 mm FITOK	6 mm FITOK						1.00 (25.4)	
MH□□-FNS2-	1/8 Female NPT	1/8 Female NPT						1.28 (32.5)	0.91 (23.1)
MH□□-FNS4-	1/4 Female NPT	1/4 Female NPT							

Optional Handles

Slotted Handle

- ⦿ Flow setting adjustment is available with a screwdriver
- ⦿ Ideal for installation where handle is difficult to access
- ⦿ Available for MS and MV series

Vernier Handle

- ⦿ Precise graduated aluminum alloy handle
- ⦿ Repeatable flow setting
- ⦿ Adjustment accurate to 1/25 turn (1/1000 of an inch)
- ⦿ Available for all series

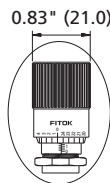
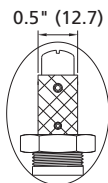

Optional Patterns

Cross Pattern

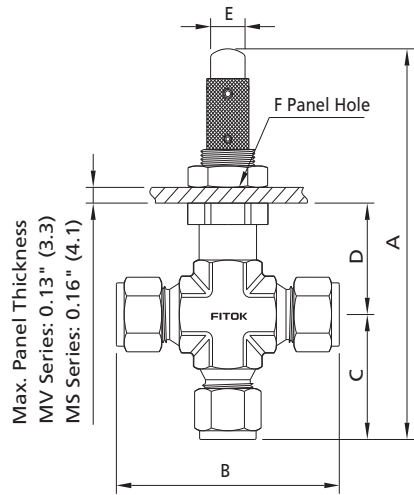
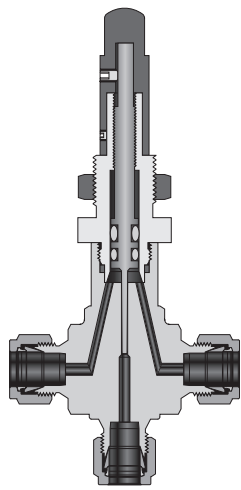

Double Pattern

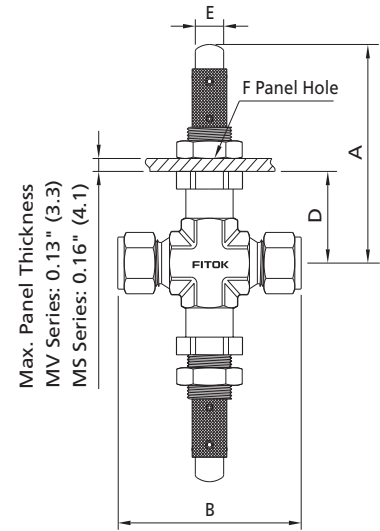
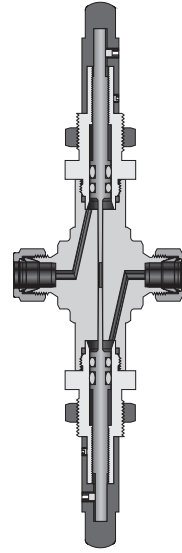

1. Fluid flows between side ports around stem in any stem position.
2. Fluid flows through branch port can be metered in both directions.

Inlet valve handle can be set and locked at desired maximum flow, outlet valve handle can be used for fine flow control up to the preset maximum of the inlet valve.

Basic Ordering Number	Connection Type and Size		Dimensions, in. (mm)					
	Inlet	Outlet	A	B	C	D	E	F
Cross Pattern								
MS□□-FL2-	1/8" FITOK	1/8" FITOK	3.32 (84.3)	1.96 (49.8)	0.98 (24.9)	0.92 (23.4)	0.38 (9.6)	0.45 (11.4)
MS□□-ML3-	3 mm FITOK	3 mm FITOK						
Double Pattern								
MS□□-FL2-	1/8" FITOK	1/8" FITOK	2.41 (61.2)	1.90 (48.3)	—	0.99 (25.2)	0.38 (9.6)	0.45 (11.4)
MS□□-ML3-	3 mm FITOK	3 mm FITOK						
Cross Pattern								
MV□□-FL4-	1/4" FITOK	1/4" FITOK	3.74 (95.0)	2.20 (55.9)	1.10 (27.9)	1.52 (38.5)	0.50 (12.7)	0.58 (14.7)
MV□□-ML6-	6 mm FITOK	6 mm FITOK						
Double Pattern								
MV□□-FL4-	1/4" FITOK	1/4" FITOK	2.62 (67.1)	2.20 (55.9)	—	1.52 (38.5)	0.50 (12.7)	0.58 (14.7)
MV□□-ML6-	6 mm FITOK	6 mm FITOK						

1. FITOK means FITOK double ferrule tube fittings, FR means metal gasket seal fittings.
2. Sizes and types listed are standard. Other sizes and types are available upon request. For special sizes and types, refer to the ordering information.
3. Dimensions are shown with FITOK nuts finger-tightened. All dimensions are for reference only and are subject to change. For dimensions not shown above, please contact FITOK Group or our authorized distributors.

Needle Valves
Metering Valves

Ordering Number Description

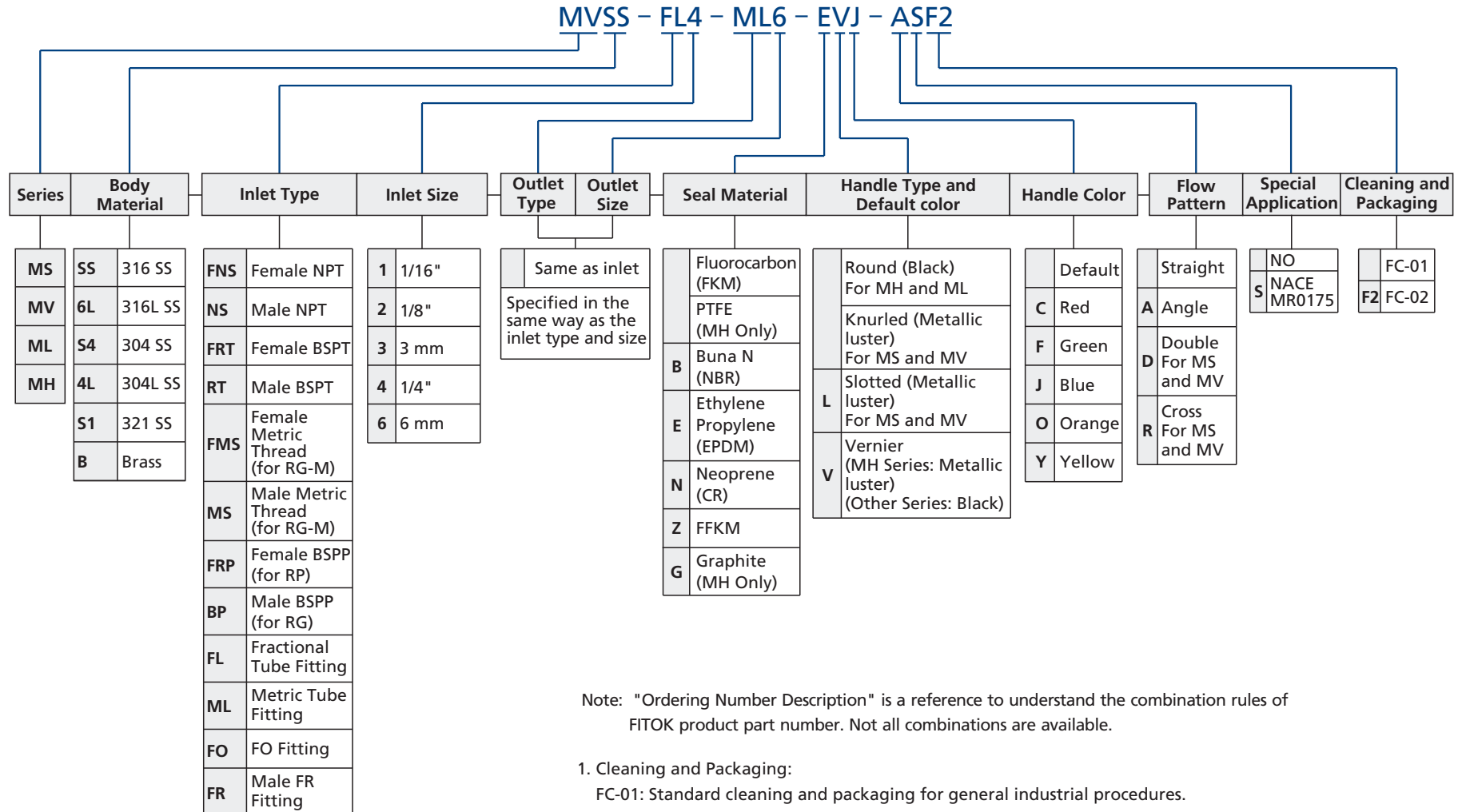

Note: "Ordering Number Description" is a reference to understand the combination rules of FITOK product part number. Not all combinations are available.

1. Cleaning and Packaging:

FC-01: Standard cleaning and packaging for general industrial procedures.

FC-02: Special cleaning and packaging for wetted system components to ensure compliance with product cleaning requirement of ASTM G93 Level C.

info@fitok.com
www.fitok.com

FK-IC-GV-05-EN-240108